



Raychem

PLI SYSTEMS

POWER LINE CARRIER TECHNOLOGY FOR HEAT-TRACING SYSTEMS

SYSTEM OVERVIEW

The Raychem PLI system consists of a PLI module, a Front End Filter assembly and a PLI End Seal or Smart Power Connector. All programming and set up is accomplished using the NGC-30 touch screen User Interface Terminal.

The PLI modules and Front End Filters are required for every installation. The PLI modules are located within the NGC-30 panel while the Front End Filter is connected to the primary side of the transformer powering the NGC-30 panel.

The PLI End Seal and Smart Power Connector both include the temperature measurement RTD and replace conventional RTD sensing elements and associated wiring.

The Smart Power Connector combines the PLI electronics and RTD with the heating cable power connection box. This allows the Raychem PLI system to be used with Pentair Industrial Heat Tracing Solutions's self-regulating, VPL and MI type heating cables.

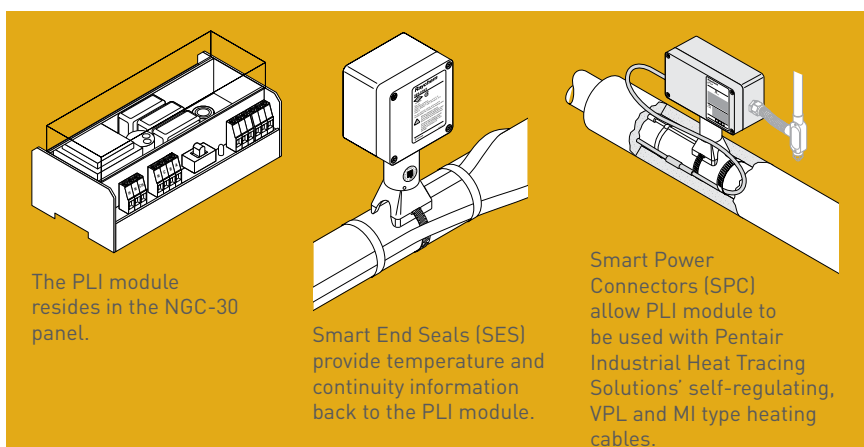

ELIMINATE THE NEED TO RUN RTD CONDUIT AND WIRING

Raychem Power Line carrier Interface (PLI) systems contribute to reduced heat management system installed costs by eliminating the need to run separate wiring and conduit between an RTD and the control panel for each heat-tracing circuit.

The Raychem PLI systems use the AC power bus wires to transmit temperature data from the PLI End Seals or Smart Power Connectors back to the Raychem NGC-30 Control & Monitoring Panel. Encoded digital data is coupled onto the AC power line and transmitted through the heat tracing and power wiring. At the NGC-30 control panel, Raychem PLI modules decode the signal and the temperature information is routed to the appropriate controller within the panel. Therefore, once the heat-tracing cable is installed, no additional RTD wiring is required.

Raychem PLI systems are available for use with Pentair Industrial Heat Tracing Solutions Raychem NGC-30 Heat-Tracing Control and Monitoring panels, which supports up to 260 PLI circuits through the User Interface Terminal (UIT).

Raychem PLI systems have been operating reliably for years at sites from the North Slope of Alaska to the desert environments of the Middle East and on to the extremes in Antarctica.



REAL INSTALLED COST SAVINGS

Pentair Raychem PLI systems provide real project cost savings by eliminating the need to install RTDs and associated conduit and wiring.

The Raychem PLI systems are easy to install and do not add to component installation time on the job site. The architecture allows cost reductions to be realized while allowing the heat-tracing control system to reside in a central location. Maintenance and Operations personnel gain fast, easy access to heat trace information through the Raychem NGC-30 touch screen UIT.

Typical savings on the Total Installed Cost of a heat-tracing system can be as much as 20% depending on the specifics of your application.

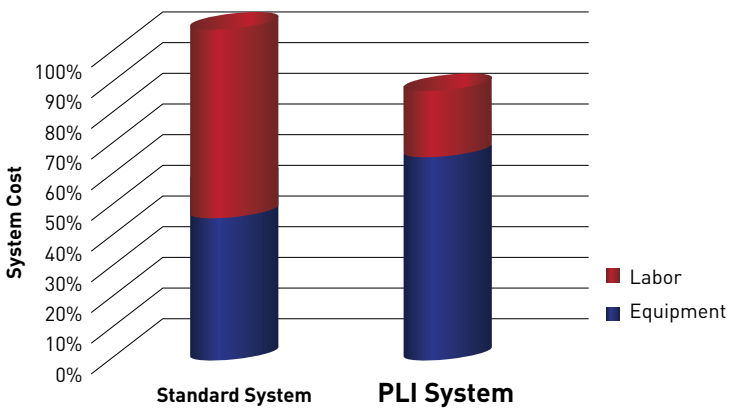

20% Savings

Ask a Pentair sales representative for estimated savings for your projects.

PLI NGC-30 TECHNOLOGY

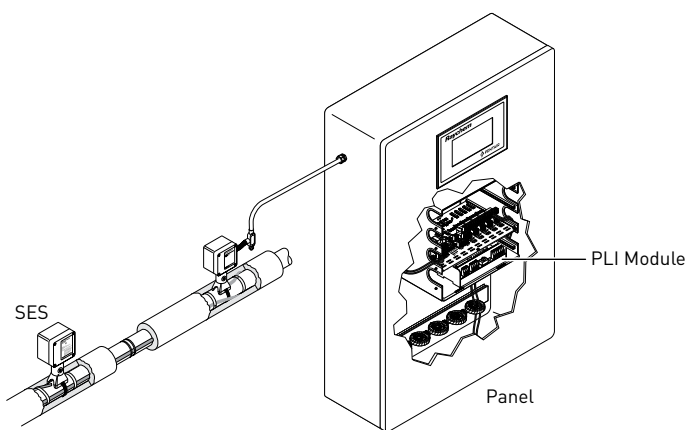

System using self-regulating cable and Smart End Seals (SES)

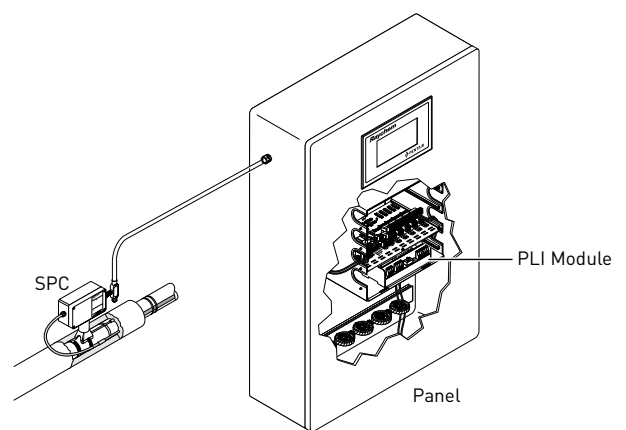

System using MI cable and Smart Power Connector (SPC)



WWW.PENTAIRTHERMAL.COM

NORTH AMERICA

Tel: +1.800.545.6258
Fax: +1.800.527.5703
Tel: +1.650.216.1526
Fax: +1.650.474.7711
thermal.info@pentair.com

EUROPE, MIDDLE EAST, AFRICA

Tel: +32.16.213.511
Fax: +32.16.213.603
thermal.info@pentair.com

ASIA PACIFIC

Tel: +86.21.2412.1688
Fax: +86.21.5426.2937
cn.thermal.info@pentair.com

LATIN AMERICA

Tel: +1.713.868.4800
Fax: +1.713.868.2333
thermal.info@pentair.com

Pentair and RMM2 are owned by Pentair or its global affiliates. All other trademarks are the property of their respective owners. Pentair reserves the right to change specifications without prior notice.

© 2006-2015 Pentair.